



METEM  
FIT



CATALOGO



#JoinTheLegion





Metem Fit's goal is to guide the client through a structured and transparent consulting process, assisting in transforming their ideas into a successful state-of-the-art fitness center.

The company aspires to become the benchmark in the national territory for the setup or renovation of fitness centers, distinguishing itself with technical expertise, innovation, and, above all, extensive experience in understanding market trends.

Throughout the years, our commitment to "go beyond" has led us to collaborate with highly experienced trainers in developing new training concepts such as RamBOX, the multi-functional bench for small group training, and Power Cuff, the innovative and versatile equipment described as "a whole gym enclosed in a circle."

Following the product development process, we personally test the products in the Training Lab located at our company headquarters. This is why we take great pride in supplying our top-quality equipment to hundreds of gyms around the world.



L'obiettivo di Metem Fit è guidare il cliente attraverso un processo di consulenza strutturato e trasparente, aiutandolo a trasformare le sue idee in un centro fitness all'avanguardia e di successo.

L'azienda aspira a diventare il punto di riferimento sul territorio nazionale per l'allestimento o il rinnovo dei centri fitness, distinguendosi per competenza tecnica, innovazione e, soprattutto, vasta esperienza nel comprendere le tendenze del mercato.

Nel corso degli anni, il nostro impegno ad "andare oltre" ci ha portato a collaborare con trainer di grande esperienza nello sviluppo di nuovi concetti di allenamento come RamBOX, la panca multifunzionale per l'allenamento in piccoli gruppi, e Power Cuff, l'attrezzatura innovativa e versatile descritta come "un'intera palestra racchiusa in un cerchio."

Dopo il processo di sviluppo, testiamo personalmente i prodotti nel Training Lab situato presso la sede della nostra azienda. Questo è il motivo per cui siamo molto orgogliosi di fornire le nostre attrezzature di alta qualità a centinaia di palestre in tutto il mondo.



**MF24**

# MAKING EPIC GYMS

Scopri il nostro percorso di consulenza volto a trasformare le tue idee in progetti concreti, con un risultato finale di successo!

## Il tuo Centro Fitness con il metodo MEG



Ascoltiamo la tua **IDEA** e la valorizzeremo insieme a te



Realizzeremo un **PROGETTO** che rispecchi ciò che hai in mente



Ti offriremo un **PERCORSO PERSONALIZZATO** per gestire il tuo progetto in maniera efficace



Vivrai una **FORMAZIONE** tecnica nel nostro Showroom



Scoprirai con i nostri esperti le migliori **SOLUZIONI FINANZIARIE** per te



Vedrai il tuo centro fitness crescere, gestiremo **INSTALLAZIONE** e **COLLAUDO** dei tuoi nuovi macchinari



*Dalla tua IDEA al PROGETTO  
in 48h!*



# 4

- . 8
  - RamBOX
- . 12
  - RamBOX-L
- . 14
  - RamBOX-S
- . 16
  - RamBOX Exercises
- . 17
  - Elastic Power Kit
- . 18
  - Power Cuff
- PERFORMANCE**
- . 22
  - Exxentric
- . 23
  - kBox
- . 24
  - kPulley2
  - kPulleyGo
  - Accessories
- . 25
  - Sportreact
- . 26
  - Lummic Reaction Lights
- . 27
  - Flowin Sport
  - Flowin Fitness
- . 28
  - Reboots
- . 30
  - Agility Ladder Pro Hex
  - Agility Ladder Hex Roll Out
  - Suspension Trainer Pro Style
- . 31
  - Zero
  - Bosu With Inflator Pump
  - Accelerator Parachute
- . 32
  - Square Wooden Balance Board
  - Wooden Balance Board Ø 39,5cm
  - Wooden Balance Board Ø 50cm
- . 33
  - Zeus Adjustable Dumbbell
  - Zeus Weighted Vest 5kg

- Zeus Weighted Vest 10kg
- .34
  - Zeus Gym Ball
  - Zeus Bosu
  - Zeus Balance Cushion
- .35
  - Zeus Folding Bench
  - Zeus Step
  - Zeus Speed Ladder
- .36
  - Zeus Ab Wheel
  - Zeus Massage Roller
  - Zeus Speed Parachute
- FUNCTIONAL**
- . 38
  - Olympic Barbell
  - Olympic Hexagonal Barbell - Shrug Bar
  - Olympic EZ Barbell
- . 39
  - Olympic Bar Collars
  - Wall Mount Barbell Storage
  - Vertical Wall Mount Barbell Storage
  - Bars Holder
- . 40
  - Classic Rubber OB Plate
  - Heavy Duty Bumper Plate
  - Steel OB Fractional Plate
- . 41
  - Training Bumper Plate
  - Pro Bumper Plate Color
  - Fractional Plate
- . 42
  - Kettlebell Competition
  - Kettlebell Pro
- . 43
  - Hexagon Dumbbell
  - Round Rubber Dumbbell
  - Steel Dumbbell
- . 44
  - Wall Ball
  - Slam Ball Pro
  - Power Bag
  - Sand Ball
- . 45
  - Weighted Vest 9kg - 10kg
  - Weighted Vest 20kg
  - Weighted Vest 30kg

- . 46
  - Timer
  - Wooden Plyobox
  - Lattex Band Set
  - Power Band
- . 47
  - Waist Belt
  - Ab Mat
  - Shock Absorption Mats
- . 48
  - Speed Ropes
  - Battle Rope
  - Climbing Rope
- . 49
  - Wooden Rings
  - Cross-Wall Anchorage Ring
  - Hand Stand Board
- . 50
  - Cross Training Sled
  - Cross Training Sled Mini
  - Dumbbell Rack
- . 51
  - Parallettes Mini
  - Parallettes Large
  - Landmine Barbell Row
- . 52
  - Dumbbell Storage 3 Shelves
  - Dumbbell Storage 2 Shelves
  - Dumbbell Storage 2 Shelves
- . 53
  - Kettlebell Storage
  - Vynil Dumbbell Storage
  - Multi Rack
- . 54
  - Body Pump Set Storage 20 set
  - Body Pump Set Storage 12 set
  - Power Bag/Wall Ball Storage

- . 55
  - Slam Ball Storage Large
  - Slam Ball Storage Small
  - Power Bag Storage
- . 56
  - Gym Ball Storage
  - Mat Storage
  - Wall Mat Storage
- . 57
  - Olympic Plate and Barbell Storage
  - Olympic Plate Storage
  - Bumper Plate Storage accessories
- . 58
  - Wall Fixing Pull Up Muscle Up Bar
  - Wall Pull Up Bar
- . 59
  - Modular & Custom Rigs
- . 60
  - Praetorian Standing Rig
- . 61
  - Centurion Wall Mounted Rig
- . 62
  - Rig Parts and Accessories
- . 63
  - Rig Parts and Accessories
- STUDIO**
- . 65
  - Vynil Dumbbell Set
  - Adjustable Dumbbell
- . 66
  - Water Bag
  - Gym Ball
  - Pilates Ball
- . 67
  - Set Body Pump
  - Body Pump Barbell
- . 68
  - Pairs of ABS Body Pump Safe Lock Ø30 mm
  - Spring Safety Collars Ø30 mm
  - Weight Body Pump Kit
- . 69
  - PVC Studio Mat With Eyelets
  - TPE Yoga Mat
- NBR Fitness Mat With Eyelets
- .70
  - Massage & Yoga Roller
  - Pilates Roller
  - Abdominal Wheel R-AB1
  - Abdominal Wheel R-AB2
- .71
  - Truck Tire
  - Soft Plyo Box Pro
  - Plyo Box Soft Pro
- .72
  - Step
  - Aerobic Step 99 x 38 cm
  - Aerobic Step 110 x 38 cm
- .73
  - Freestanding Punching Bag
  - Fit Boxe Bag
- .74
  - Boxing Bag
  - Punching Bag Plain
- .75
  - Swedish One-Span Wall Bars
  - Swedish Double-Span Wall Bars
- .76
  - Superfici Tecniche
- .77
  - Virtus
  - Virtus-s
  - Interlock Tiles
- .78
  - Rubber Roll
  - Tatami
  - Artificial Turf Comfort
  - Artificial Turf Sled Path
- .79
  - Sprint Track
- .80
  - Magnitudo
  - Olympic Lifting Platform
  - Flooring Clean System
- .81
  - Air Bike
  - RowErg
- .82
  - RunMill
  - Exercycle

# MAKE YOUR EPIC GYM



Scopri nelle nuove sezioni  
“**PERFORMANCE**”,  
“**FUNCTIONAL**” e  
“**STUDIO**”, come allestire al  
meglio la tua area

Find in the Catalogue the following  
icons: **C** (customizable colour) - **L**  
(customizable logo) - **Italian Flag**  
(made in Italy)

Trovi le seguenti icone nel Catalogo:  
**C** (colore personalizzabile) - **L** (logo  
personalizzabile) - **Bandiera italiana**  
(made in Italy)



\*Contattaci per avere i cataloghi delle macchine cardio e strength professionali

# 01

Strength



# 02

Cardio



# 03

Accessories



# 04

Training Floorings



# RamBOX



RamBOX is a multi-functional station designed to optimize workspace utilization, serving as the focal point of the training area by incorporating various functions into a single solution. From functioning as a jump box to a sled, it also serves as an adjustable bench and anchoring point for training with rubber bands or ropes.

The objective is to empower trainers to efficiently manage workspace while providing users with the broadest array of exercise options, ensuring a comprehensive and effective training experience.

The concept for RamBOX originated from Igor Castiglia, aiming to extract maximum value from space organization in Personal Training and Small Group workouts.



RamBOX è una stazione multifunzionale progettata per ottimizzare l'utilizzo dello spazio di lavoro, fungendo da punto focale dell'area training e incorporando diverse funzioni in un'unica soluzione. Da jump box a slitta, funge anche da panca regolabile e da punto di ancoraggio per l'allenamento con elastici o corde.

L'obiettivo è consentire ai trainer di gestire in modo efficiente lo spazio di lavoro fornendo agli utenti la più ampia gamma di opzioni di esercizio, garantendo un'esperienza di formazione completa ed efficace.

Il concetto di RamBOX è stato sviluppato da Igor Castiglia, con l'obiettivo di estrarre il massimo valore dall'organizzazione dello spazio nel Personal Training e negli allenamenti in piccoli gruppi.







## SCEGLI IL TUO COLORE PREFERITO

-  *Alluminio*
-  *Bianco*
-  *Arancione*
-  *Giallo*
-  *Grigio*
-  *Verde*
-  *Rosso*
-  *Blu*

**Altri colori  
su richiesta...**



**L** LOGO

**PERSONALIZZA**  
-LOGO  
-GRAFICA  
*con pannello  
magnetico*



# 10 RamBOX



## NAKED

CODE	DIMENSIONS (cm)	WEIGHT (kg)
LGRB000	140 x 40 x 48	85



## WHITE PACK

CODE	PRODUCT	WEIGHT (kg)
LGRB001	White Pack	155

Including:

- > Hex Dumbbell Chrome pairs: 5kg – 7,5kg – 10kg - 12,5kg



## BLACK PACK

CODE	PRODUCT	WEIGHT (kg)
LGRB002	Black Pack	180

Including:

- > Hex Dumbbell Chrome pairs: 5kg – 7,5kg – 10kg - 12,5kg
- > SandBall X-treme up to 12kg
- > Kettlebell PRO 8kg – 12kg



## GOLD PACK

CODE	PRODUCT	WEIGHT (kg)
LGRB003	Gold Pack	200

Including:

- > Hex Dumbbell Chrome pairs: 5kg – 7,5kg – 10kg - 12,5kg
- > SandBall X-treme up to 12kg
- > Kettlebell PRO 8kg – 12kg
- > Battle Rope 9m x 38mm
- > Power Band: Black - Purple - Green - Blue



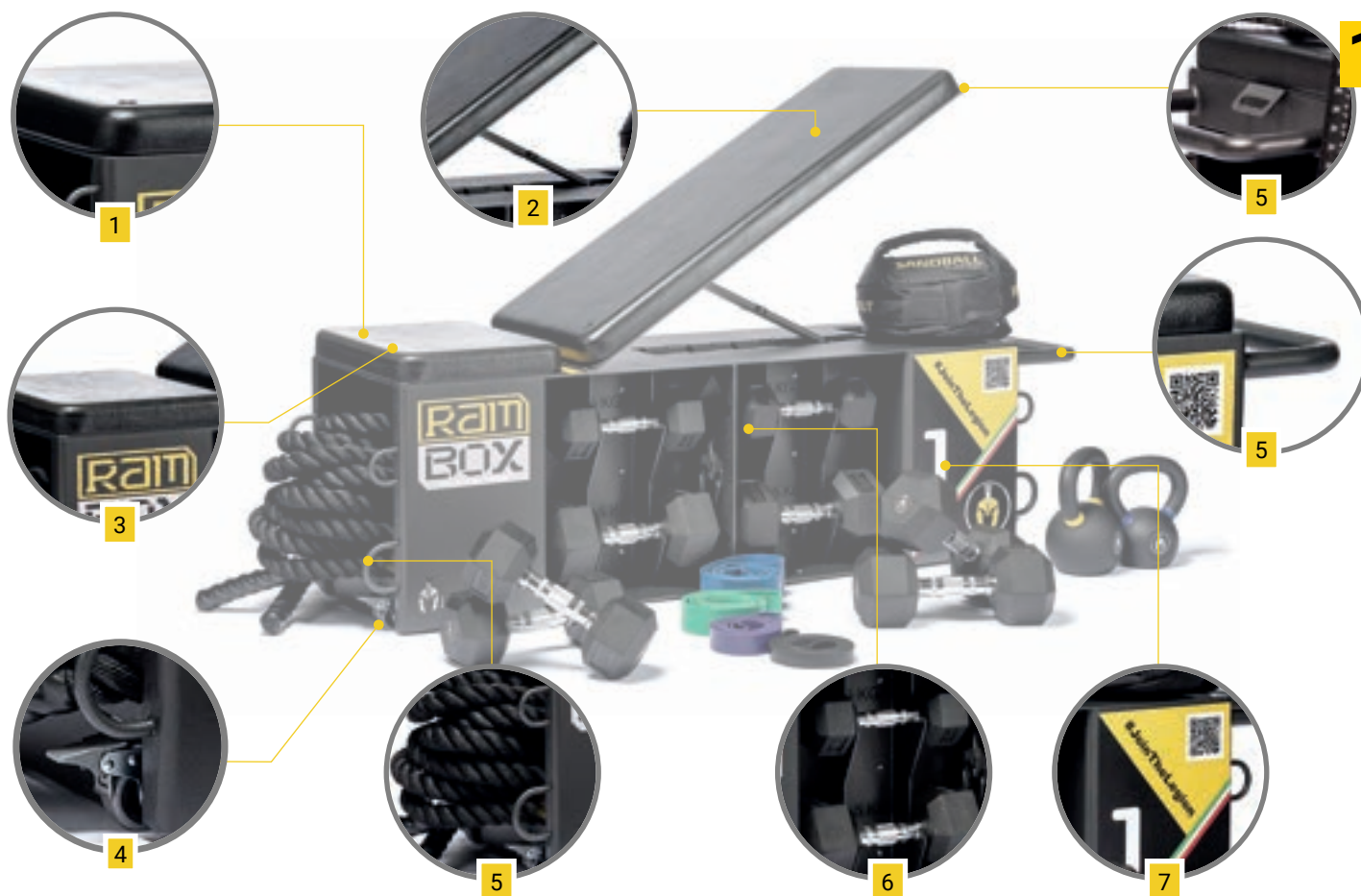

### 1. FLAT BENCH

The backrest provides the right comfort and a strong support. The designed handle allows to have a safe and easy grip while performing core-training exercises or dips.

*Lo schienale offre il giusto comfort e sostegno.*

*La maniglia consente di avere una presa sicura e comoda durante l'esecuzione degli esercizi.*

### 2. ADJUSTABLE BENCH

4 different positions, it can be easily moved to be used in combination with a power rack.

*4 differenti inclinazioni, può essere facilmente utilizzata in combinazione con un rack.*

### 3. STEP BOX / JUMP BOX

The height has been studied to allow a correct use as a step box (knee angle at 90°) and a safe use of it as a jump box, thanks to the 40cm width of the landing area.

*L'altezza è stata studiata per consentire un uso corretto come step (angolo del ginocchio a 90°) ed un sicuro utilizzo come box jump, grazie ai 40cm di larghezza del piano di appoggio.*

### 4. SLED

Push/pull mode thanks to the 4 wheels (with easy-lock brakes) and the use of the handle in combination with the battle rope.

*Modalità push/pull grazie alle 4 ruote (con freni) e all'uso della maniglia in combinazione con la battle rope.*

### 5. ANCHORING POINTS

10 anchoring points to work with the battle rope and the elastic kit.

*10 punti di ancoraggio per l'allenamento con la battle rope e l'elastic kit.*

### 6. RACK

To organize Hex Dumbbells – Kettlebells – Battle Rope Sand Ball. The width of the dumbbell rack is adjustable.

*Per tenere in ordine gli Hex Dumbbell – Kettlebell – Battle Rope Sand Ball. La larghezza del rack porta manubri è regolabile.*

### 7. CUSTOMIZATION

Customizable Logo and Color.

*Personalizzabile con Logo e Colore.*

# 12 RamBOX-L



## NAKED

CODE	DIMENSIONS (cm)	WEIGHT (kg)
LGRB030	140 x 40 x 48	65



## WHITE PACK

CODE	PRODUCT	WEIGHT (kg)
LGRB031	White Pack	135

Including:

- > Hex Dumbbell Chrome pairs: 5kg – 7,5kg – 10kg - 12,5kg



## BLACK PACK

CODE	PRODUCT	WEIGHT (kg)
LGRB032	Black Pack	160

Including:

- > Hex Dumbbell Chrome pairs: 5kg – 7,5kg – 10kg - 12,5kg
- > SandBall X-treme up to 12kg
- > Kettlebell PRO 8kg – 12kg



## GOLD PACK

CODE	PRODUCT	WEIGHT (kg)
LGRB033	Gold Pack	180

Including:

- > Hex Dumbbell Chrome pairs: 5kg – 7,5kg – 10kg - 12,5kg
- > SandBall X-treme up to 12kg
- > Kettlebell PRO 8kg – 12kg
- > Battle Rope 9m x 38mm
- > Power Band: Black - Purple - Green - Blue





### 1. FLAT BENCH

The backrest provides the right comfort and a strong support. The designed handle allows to have a safe and easy grip while performing core-training exercises or dips.

*Lo schienale offre il giusto comfort e sostegno.*

*La maniglia consente di avere una presa sicura e comoda durante l'esecuzione degli esercizi.*

### 2. ADJUSTABLE BENCH

4 different positions, it can be easily moved to be used in combination with a power rack.

*4 differenti inclinazioni, può essere facilmente utilizzata in combinazione con un rack.*

### 3. STEP BOX / JUMP BOX

The height has been studied to allow a correct use as a step box (knee angle at 90°) and a safe use of it as a jump box, thanks to the 40cm width of the landing area.

*L'altezza è stata studiata per consentire un uso corretto come step (angolo del ginocchio a 90°) ed un sicuro utilizzo come box jump, grazie ai 40cm di larghezza del piano di appoggio.*

### 4. EASY TO MOVE

Thanks to the 2 wheels it can be easily moved.

*Grazie alle 2 ruote incorporate può essere facilmente spostata.*

### 5. ANCHORING POINTS

4 anchoring points to work with the battle rope and the elastic kit.

*4 punti di ancoraggio per l'allenamento con la battle rope e l'elastic kit.*

### 6. RACK

To organize Hex Dumbbells – Kettlebells – Battle Rope Sand Ball. The width of the dumbbell rack is adjustable.

*Per tenere in ordine gli Hex Dumbbell – Kettlebell – Battle Rope SandBall. La larghezza del rack porta manubri è regolabile*

### 7. CUSTOMIZATION

Customizable Logo and Color.

*Personalizzabile con Logo e Colore.*

## TECHNICAL INFORMATION

RamBOX	RamBOX-L
4 wheels	2 wheels
10 anchoring points	4 anchoring points
Adjustable backrest in 4 positions	Adjustable backrest in 4 positions
85 kg	65 kg
140 x 40 x 48 cm	140 x 40 x 48 cm

# 14 RamBOX-S



## NAKED

CODE	DIMENSIONS (cm)	WEIGHT (kg)
LGRB010	106 x 40 x 45	55



## WHITE PACK

CODE	PRODUCT	WEIGHT (kg)
LGRB011	White Pack	90

Including:

- > Hex Dumbbell Chrome pairs: 5kg – 7,5kg – 10kg



## BLACK PACK

CODE	PRODUCT	WEIGHT (kg)
LGRB012	Black Pack	115

Including:

- > Hex Dumbbell Chrome pairs: 5kg – 7,5kg – 10kg
- > SandBall X-treme up to 12kg
- > Kettlebell PRO 8kg – 12kg



## GOLD PACK

CODE	PRODUCT	WEIGHT (kg)
LGRB013	Gold Pack	130

Including:

- > Hex Dumbbell Chrome pairs: 5kg – 7,5kg – 10kg
- > SandBall X-treme up to 12kg
- > Kettlebell PRO 8kg – 12kg
- > Battle Rope 9m x 38mm
- > Power Band: Black - Purple - Green - Blue





### 1. FLAT BENCH

The backrest provides the right comfort and a strong support.

The designed handle allows to have a safe and easy grip while performing core-training exercises or dips.

*Lo schienale offre il giusto comfort e sostegno.*

*La maniglia consente di avere una presa sicura e comoda durante l'esecuzione degli esercizi.*

### 2. STEP BOX / JUMP BOX

The height has been studied to allow a correct use as a step box (knee angle at 90°)

and a safe use of it as a jump box, thanks to the 40cm width of the landing area.

*L'altezza è stata studiata per consentire un uso corretto come step (angolo del ginocchio a 90°)*

*ed un sicuro utilizzo come box jump, grazie ai 40cm di larghezza del piano di appoggio.*

### 3. ANCHORING POINTS

5 anchoring points to work with the battle rope and the elastic kit.

*5 punti di ancoraggio per l'allenamento con la battle rope e l'elastic kit.*

### 4. RACK

To keep Hex Dumbbells - Kettlebells - Battle rope - Sandball in order.

*Per tenere in ordine gli Hex Dumbbell - Kettlebell - Battle Rope - Sandball.*

### 5. EASY TO MOVE

Thanks to the 2 wheels (with easy-lock brakes).

*Facile da spostare grazie alle 2 ruote (con freni)*

### 6. CUSTOMIZATION:

Customizable Logo and Color

*Personalizzabile con Logo e Colore*

# 16 RamBOX EXERCISES



1 Exercise - **Bench Dips**



2 Exercise - **High Frontal Raise**



3 Exercise - **Elastic Chest Press**



4 Exercise - **Half dragon flags**



5 Exercise - **Incline Dumbbell Press**



6 Exercise - **Step Ups**



→ find more exercises on [www.rambox.it](http://www.rambox.it)



# ELASTIC POWER KIT

17

CODE	DIMENSIONS (cm)	WEIGHT (kg)
LGRBP001	90 x 15 x 15	3



## Including:

Covered Power Tube HEAVY - 170cm  
Covered Power Tube MEDIUM - 120cm  
Covered Power Tube LIGHT - 120cm  
Light Core Stick - 80cm x 3mm  
Handles pair  
Light Power Vest  
Long anchor  
Packing Bag - 44 x 48cm

- > Allows to perform a wide range of exercises
- > Easy to transport thanks to the packaging bag
- > For body weight and core strength exercises

- > Permette di eseguire una vasta gamma di esercizi
- > Facile da trasportare grazie alla packing bag
- > Per esercizi a corpo libero e core strength

**“LET THE  
WEIGHT BECOME  
PART OF YOUR  
BODY WITH  
POWER CUFF”**



**POWER CUFF** WAS DEVELOPED IN COLLABORATION WITH THE MASTER TRAINER **GUIDO BRUSCIA**, FOUNDER AND TECHNICAL DIRECTOR OF FUNCTIONAL TRAINING SCHOOL.

THANKS TO HIS KNOWLEDGE AND EXPERTISE WE CREATED **POWER CUFF** THE INNOVATIVE AND VERSATILE EQUIPMENT, WHICH CAN BE DESCRIBED AS **"THE GYM IN A CIRCLE"**

**POWER CUFF** È STATO SVILUPPATO IN COLLABORAZIONE CON IL MASTER TRAINER **GUIDO BRUSCIA**, FONDATORE E DIRETTORE TECNICO DI FUNCTIONAL TRAINING SCHOOL IN ITALIA.

GRAZIE ALLA SUE CONOSCENZE E COMPETENZE ABBIAMO CREATO **POWER CUFF**, L'INNOVATIVO E VERSATILE ATTREZZO, CHE VIENE DESCRITTO COME **"LA PALESTRA IN UN CERCHIO"**

**Power Cuff will change your training:**

- > The inside handle gives a balanced distribution of the load
- > The weight becomes part of your body allowing a greater stability and movement control even with a high loads
- > Allows to safely perform a wide range of exercises such ballistic exercises and dynamic exercises
- > No high technical skills are required
- > Space-saving and no racks needed, thanks to power cuff' shape you can arrange them in a pile
- > **Available in 2 different versions:**  
Power Cuff PRO  
Power Cuff Élite
- > **Equipment officially approved by:**  
FUNCTIONAL TRAINING SCHOOL
- > The specific design is registered by **Metem srl**



**Con Power Cuff scoprirai una nuova dimensione di allenamento:**

- > La presa interna consente una distribuzione equilibrata del carico
- > Il peso diventa parte del corpo conferendo una maggiore stabilità e controllo del movimento
- > Consente un utilizzo sicuro anche con carichi elevati
- > Non sono richieste competenze tecniche elevate
- > Salva spazio, la loro particolare forma permette di impilarli facilmente senza la necessità di porli sul rack.
- > **Disponibile in 2 versioni:**  
Power Cuff PRO  
Power Cuff Élite
- > **Power Cuff è ufficialmente approvato da**  
FUNCTIONAL TRAINING SCHOOL:
- > Il design specifico è stato registrato da **Metem srl**



# POWER CUFF PRO

CODE	WEIGHT (kg)
LG00901	4
LG00902	6
LG00903	8
LG00904	10
LG00905	12
LG00906	14
LG00907	16
LG00908	18
LG00909	20



- > Powder coated
- > 31mm central pro-grip handle for a better control during the movement
- > 13,6cm width internal handle for a better stability

# POWER CUFF ÉLITE

CODE	WEIGHT (kg)
LG00924	4
LG00926	6
LG00928	8
LG00930	10
LG00932	12



- > Vinyl coated
- > 31mm central pro-grip handle for a better control during the movement
- > 13,6cm width internal handle for a better stability

# PERFORMANCE



**kBox & the kPulley2**

are specific devices for flywheel training.

The load depends on how hard you pull or push and it will adjust to your strength to create optimal resistance.

Flywheel training also offers eccentric overload, which is potent in late stage rehab or in injury prevention.

Flywheel training has been shown to be a potent stimulus for gains in strength and mass in athletes, seniors and patients.

Le pedane **kBox** ed il **kPulley2** di **Exxentric** sono dispositivi specifici per l'allenamento isoinerziale.

Il flywheel training permette di lavorare con un sovraccarico importante nella fase eccentrica, molto utile nella riabilitazione così come nella prevenzione delle lesioni.

Inoltre è efficace nel migliorare la forza ed aumentare la massa muscolare negli sportivi, negli anziani e nei pazienti in fase di riabilitazione.

**The variable resistance allows for:**

- > Max load over the whole range of motion without sticking points
- > Fast and seamless transitions between users and exercises
- > Individual load based on user's level of strength, pain and intensity

The **kMeter II** feedback system is built-in for the **kBox Pro**, **kBox Lite** and the **kPulley2** and compatible with the **kBox4 Active**.

The **kMeter** app is downloaded from your app store and provides real time metrics on peak and average power, force and velocity.

**Exxentric devices offer a number of important advantages:**

- > Ease of use
- > Wide range of exercises
- > Small footprint (less than 1sqm)
- > Lightweight & portability.

**La resistenza variabile consente di:**

- > Avere un carico massimale per l'intera durata dell'allenamento
- > Velocizzare i tempi di transizione tra diversi esercizi o tra diversi utenti
- > Utilizzare un carico sempre calibrato sul livello dell'utente, in base alla sua forza e all'intensità desiderata

Il sistema di rilevazione **kMeter II**, integrato sulle pedane **kBox Pro - kBox Lite** e **kPulley2** (compatibile anche con **kBox Active**) monitora da Smartphone o Tablet: potenza generata, forza eccentrica/concentrica, velocità e range di movimento.

**Le attrezzature Exxentric offrono alcuni importanti vantaggi:**

- > Facilità di utilizzo
- > Vasta gamma di esercizi
- > Ingombro ridotto (meno di 1mq)
- > Leggero e portatile

## KBOX ACTIVE

CODE	DIMENSIONS (cm)	MATERIAL	COLOR
EX18244	76 x 51 x 21	Steel	Jet Black



- > It is suitable for all levels of users
- > Ideal for gym studios, group classes, amateur athletes
- > Inertia capacity goes up to 0.100 kgm<sup>2</sup>

- > Adatto a utenti di tutti i livelli
- > Ideale per palestre, corsi di gruppo, atleti amatoriali
- > Inerzia fino a 0,100 kgm<sup>2</sup>

## KBOX LITE

CODE	DIMENSIONS (cm)	MATERIAL	COLOR
EX18264	76 x 51 x 21	Aluminium	Midnight Blue - Carbon Black



- > Perfect for users who frequently travel (just 9.5kg)
- > kMeter II feedback system included
- > Maximum inertia level of 0,300 kgm<sup>2</sup>

- > Ideale per utenti che viaggiano spesso (solo 9.5kg)
- > Sistema di rilevazione dati kMeter II incluso
- > Inerzia fino a 0,300 kgm<sup>2</sup>

## KBOX PRO

CODE	DIMENSIONS (cm)	MATERIAL	COLOR
EX18265	98 x 53 x 23	Aluminium	Midnight Blue - Carbon Black



- > Ideal for sports teams, premium fitness clubs and physiotherapy clinics
- > kMeter II feedback system included
- > Maximum inertia level of 0,420 kgm<sup>2</sup>

- > Ideale per team sportivi, per grandi club fitness e cliniche fisioterapiche
- > Sistema di rilevazione dati kMeter II incluso
- > Inerzia fino a 0,420 kgm<sup>2</sup>

## KPULLEY2

CODE	DIMENSIONS (cm)	MATERIAL	COLOR
EX18257	23 x 21 x 180/220	Aluminium	Midnight Blue - Jet Black

- > The **kPulley2** is the ideal horizontal solution for improving strength by offering flywheel training for rotational and pull exercises.
- > Customizable with Exxentric accessories.

- > Il **kPulley2** è ideale per migliorare la forza, eseguendo esercizi di rotazione e trazione sul piano orizzontale.
- > Personalizzabile con gli accessori Exxentric.



## KPULLEY GO

CODE	DIMENSIONS (cm)	COLOR
EX18240	39,4 x 41,2 x 19	Jet Black

- > The **kPulleyGo** is a great solution for improving strength by offering flywheel training for rotational and pull exercises.
- > Suitable for indoor and outdoor training.
- > Easy to install wherever you want.

- > Il **kPulleyGo** è ideale per migliorare la forza, eseguendo esercizi di rotazione e trazione sul piano orizzontale.
- > Ottimo sia per allenamenti indoor che all'aperto..
- > Facile da installare ovunque tu voglia.



## ACCESSORIES / ACCESSORI



- 1 Harness front EX18901
- 2 Hip Belt EX18301
- 3 kGrips EX19057
- 4 Ankle Cuffs EX19053
- 5 Foot Block EX19142
- 6 Decline-Calf raise board EX19011
- 7 kBar EX19055
- 8 Standard Flywheels black
- 9 Color Coded Flywheels



# SPORTREACT

## DEPTH EVALUATION OF ATHLETIC PERFORMANCE

- > Reaction System: train the brain to react quickly to the stimulus
- > Timing System: improve the ability to change position and or direction with speed and accuracy
- > Reactive agility system: perform a change of direction drill running and reactin to an external stimulus in unplanned situation

## ATTENTA VALUTAZIONE DELLE PRESTAZIONI ATLETICHE

- > Sistema di reazione: allena il cervello a reagire rapidamente allo stimolo
- > Sistema di cronometraggio: migliorare la capacità di cambiare posizione e/o direzione con velocità e precisione
- > Sistema di agilità reattiva: eseguire un esercizio di cambio di direzione correndo e reagendo ad uno stimolo esterno in situazioni non pianificate

## DATA-BASED PROGRESS

- > Get instant workout results
- > Compare individual and team results
- > Make important decisions

## KIT INCLUDES

- > 6 devices
- > 6 suction cups
- > 6 tripods
- > 2 carrying bags
- > 1 battery charger



## ANALISI DEI PROGRESSI BASATI SUI DATI

- > Ottieni risultati immediati
- > Confronta i risultati individuali e di squadra
- > Prendi decisioni importanti

## KIT INCLUDE

- > 6 dispositivi
- > 6 ventose
- > 6 treppiedi
- > 2 borse
- > 1 carica batteria



# LUMMIC REACTION LIGHTS

CODE	UNIT
PI-TF700103	4
PI-TF700105	8

- > Auditory and light reaction system
- > Designed for development of speed, reflexes, reaction capacity, elements association, space distribution, memory
- > 4 different audience and you need the same for any of them: Lummic Pack + Official Lummic App

- > Sistema di allenamento basato su reazioni luminose e uditive
- > Creato per sviluppare velocità, riflessi, capacità di reazione, associazione di elementi, distribuzione dello spazio, memoria
- > 4 categorie di target ma un unico pacchetto Lummic + App ufficiale



## KIT INCLUDES

- > 4 straps for fastening to the body
- > 4 fixing suction cups
- > 4 fixing magnets
- > Transport bag
- > USB charging wire

## KIT INCLUDE

- > 4 cinghie per il fissaggio al corpo
- > 4 ventose
- > 4 magneti
- > 4 ganci a punta
- > Bag
- > Cavo di ricarica USB

## FLOWIN SPORT

CODE	DIMENSIONS (cm)
11014	138 x 98

- > Rollable and portable board suitable for home and travelling



- > Tappetino pieghevole e portatile adatto ad un utilizzo home e in viaggio

## FLOWIN FITNESS

CODE	DIMENSIONS (cm)
11037	98 x 68

- > Easy to bring with you
- > It comes with a travel bag for easy transportation



- > Facile da portare ovunque
- > In dotazione una comoda borsa per il trasporto



- > FLOWIN® Friction Training™ is a high intensity, low impact training concept which leverages gravity, the user's own body weight and the FLOWIN® Board's patented friction surface to produce an endless range of dynamic exercises

- > FLOWIN® Frinction Training™ è un allenamento ad alta intensità e a basso impatto che sfrutta la gravità, il peso corporeo dell'utente e la superficie di atrito brevettata di FLOWIN® Board per produrre una gamma infinita di esercizi dinamici

## REBOOTS

<i>CODE</i>	<i>MODEL</i>	<i>FEATURES</i>
RB-141	One with pants 2.0	8 Chambers, 6 massage programmes, 240 mmHg
RB-059	Go with pants	6 chambers, 4 Massage programmes, 240 mmHg, portable
RB-097	One Lite with Pants	6 Chambers, 6 massage programmes, 240 mmHg
RB-105	Go Lite with boots (M)	4 chambers, portable
RB-106	Go Lite with boots (L)	4 chambers, portable
RB-107	Go Lite with boots (XL)	4 chambers, portable
RB-130	Go Lite with Pants 2.0	4 chambers, portable
RB-139	One Pro with Pants 2.0	12 chambers, 8 Programmes, customizable chambers





1 Reboots One



2 Reboots Go



3 Reboots One Lite



4 Reboots Go Light



5 Reboots One Pro

- 
- > You are recoverd faster
  - > Your legs feel lighter
  - > You can train again faster

- 
- > The more chambers, the smoother and more effective the massage
  - > The massage should not be too weak and not to strong. Adjust the pressure to your need
  - > Boots massage your legs, while pants additionally cover the gluteus (gluteal muscle). Pants therefore massage a larger area than boots

- 
- > Rapido recupero dopo l'allenamento
  - > Le gambe sono più leggere
  - > Puoi iniziare una nuova sessione di allenamento più velocemente

- 
- > Maggiore è il numero di camere, più fluido ed efficace sarà il massaggio
  - > Il massaggio non deve essere nè troppo debole nè troppo forte: regola la pressione in base alle tue esigenze
  - > Gli stivali massaggiano le gambe, mentr i pantaloni coprono anche i glutei. I pantaloni, quindi, massaggiano un'area più ampia rispetto agli stivali

## AGILITY LADDER – PRO HEX

### CODE

LGJ-AL-P

- > Convenient yellow PVC folding ladder. Variant on the classic agility ladder. Completely foldable thanks to the of "easy-folding" connectors



## AGILITY LADDER HEX – ROLL-OUT

### CODE

LGJ-AL-R

### DIMENSIONS

41 x 454 cm x 3 mm

- > Recycled rubber variant of the classic agility ladder. The strip has 10 steps



## SUSPENSION TRAINER PRO SYLE

### CODE

LG00420

### HANDLE (mm)

28

- > Suitable for a total body workout
- > Different anchoring systems



# ZERO



<i>CODE</i>	<i>DIMENSIONS (cm)</i>
LG01033	diam. 70 - h 18/15

- > Proprioceptive platform
- > Improves coordination and stability by simulating dynamic situation



# BOSU WITH INFLATOR PUMP

<i>CODE</i>	<i>DIMENSIONS (cm)</i>
LGJ-BOS-P	diam. 59 - h 26

- > Is an inflatable soft rubber hemisphere that features a rigid circular base with a protective rim.



# ACCELERATOR PARACHUTE

<i>CODE</i>
LGJ-PAR

- > Nylon made, it couples to the main sail a stabilizer device to optimize the resistance.



## SQUARE WOODEN BALANCE BOARD

<i>CODE</i>	<i>WEIGHT (kg)</i>
LGJ-BBQD	Max user weight: 200

> 50 x 50 cm - Thickness 1,6 cm - Height from ground 6,2 cm



## WOODEN BALANCE BOARD Ø 39,5 CM

<i>CODE</i>	<i>WEIGHT (kg)</i>
LGJ-BBD39,5	Max user weight: 250

> Diameter 39.5 cm. Depth 1,5 cm



## WOODEN BALANCE BOARD Ø 50 CM

<i>CODE</i>	<i>WEIGHT (kg)</i>
LGJ-BBD50	Max user weight: 200

> Diameter 50 cm - Thickness 1,6 cm





## ZEUS ADJUSTABLE DUMBBELL

<i>CODE</i>	<i>WEIGHT (kg)</i>
LGZ-DUMBBELL REGOL	25 max

- > 4 discs per side
- > Adjustable weight
- > Non-slip handle
- > Can be locked on a solid and compact base



## ZEUS WEIGHTED VEST 5KG

<i>CODE</i>	<i>WEIGHT (kg)</i>
LGZ-G/ZAVORRA 5	5 max

- > 100% Neoprene filled with iron sand



## ZEUS WEIGHTED VEST 10KG

<i>CODE</i>	<i>WEIGHT (kg)</i>
LGZ-G/ZAVORRA 10	10 max

- > 100% Neoprene filled with iron sand



## ZEUS GYM BALL

<i>CODE</i>	<i>DIMENSIONS (cm)</i>
LGZ-GYM BALL 75	Ø 75

- > Fitness ball for strengthening deep muscles. Strengthens the fascia abdominal, tones the silhouette and relieves back pain



## ZEUS BOSU

<i>CODE</i>	<i>DIMENSIONS (cm)</i>
LGZ-BOSU BALL	Ø 62/ h 25/

- > Supports a weight of 140 kg.
- > Capacity 100 kg. For domestic use



## ZEUS BALANCE CUSHION

<i>CODE</i>	<i>DIMENSIONS (cm)</i>
LGZ-MEDUSA BALANCE	Ø 33

- > Improves posture, balance and increases proper blood circulation
- > Colour: Yellow Fluo.



# ZEUS FOLDING BENCH

<i>CODE</i>	<i>DIMENSIONS (cm)</i>
LGZ-FOLDING BENCH	121,2 x 33 x 20

- > Plastic with rubber surface coating
- > With variable height: 20 cm and 35,5 cm



# ZEUS STEP

<i>CODE</i>	<i>DIMENSIONS (cm)</i>
LGZ-STEP	67x27x15

- > Plastic with non-slip rubber coating on the surface



# ZEUS SPEED LADDER

<i>CODE</i>	<i>DIMENSIONS (cm)</i>
LGZ-SCALA A PIOLI	6 x 0,50

- > Ladder for motor coordination exercises.
- > Carrying bag including



## ZEUS AB WHEEL

<i>CODE</i>	<i>DIMENSIONS (cm)</i>
LGZ-AB Wheel	32 x 15 x 15

- > Training wheel for abdominal muscle
- > Comfortable grip



## ZEUS MASSAGE ROLLER

<i>CODE</i>	<i>DIMENSIONS (cm)</i>
LGZ-RULLOMUSCOLARE	h 33 - Ø 13

- > Foam roller with a solid and smooth structure.
- > Self-massage and myofascial dissolution.



## ZEUS SPEED PARACHUTE

<i>CODE</i>	<i>DIMENSIONS (cm)</i>
LGZ-SPEED PARAC	55x30

- > Nylon parachute for speed and endurance training.
- > Perfect for running and football.
- > It opens as soon as the race begins.





**FUNCTIONAL**

# OLYMPIC BARBELL

MAN & WOMAN



CODE PRO	VERSION	PRODUCT	LENGHT (cm)	BEARING	PSI
LG00565P	MAN - 20 kg	Max Load: 450 kg	220	4	160.000
LG00564P	WOMAN - 15 kg	Max Load: 150 kg	201	2	

- > 28 - 25mm handle diameter man / woman
- > Knurl marks

# OLYMPIC HEXAGONAL BARBELL – SHRUG BAR



CODE	VERSION	PRODUCT	LENGHT (cm)	WEIGHT (kg)
LGJ-BOED-P	300 kg	Max Load: 300 kg	160	23
LGJ-BOEDN	200 kg	Max Load: 200 kg	155	20

- > 50 mm handle diameter

# OLYMPIC EZ BARBELL



CODE	PRODUCT	LENGTH (cm)
LGJ-BE2D	Max Load: 150 kg	120

# OLYMPIC BAR COLLARS

## EASY LOCK

<i>CODE</i>	<i>PRODUCT</i>
LG00602	Plastic
LG00603	Aluminium



> Quick lock and release

# WALL MOUNT BARBELL STORAGE

<i>CODE</i>	<i>DIMENSIONS (cm)</i>
LGJ-RLGJ-B-6W	5,5 x 6,2 x 110 cm

> Thanks to its two steel uprights, allows up to 6 barbells to be stowed on the wall in the specially shaped slots.



# VERTICAL WALL MOUNT BARBEL STORAGE

<i>CODE</i>	<i>DIMENSIONS (cm)</i>
LGJ-RBW-3	30,5 x 11 x 8

> 3 seats wall mount barbell storage. Equipped with PE protective pads allows to store the bars safeguarding the finishing



# BARS HOLDER

## METAL BARS HOLDER

<i>CODE</i>	<i>WEIGHT (kg)</i>	<i>COLOR</i>
LG00702	10	Black
LG00722	20	Black



LG00702



> Holds up to 9 barbells

## CLASSIC RUBBER OB PLATE



CODE	WEIGHT (kg)	Ø INNER HOLE (mm)
LG00850	1,25	50
LG00851	2,5	50
LG00852	5	50
LG00853	10	50
LG00854	15	50
LG00855	20	50
LG00856	25	50



- > Multiple and ergonomic grips for olympic bar, racks and other plates-loaded equipment

## HEAVY DUTY BUMPER PLATE



CODE	WEIGHT (kg)	THICKNESS (cm)
F00810C	5	3
F00811C	10	6
F00812C	15	9
F00813C	20	12



- > Indoor and outdoor use
- > Noise reduction
- > Preserves bars and surfaces

## STEEL OB FRACTIONAL PLATE



CODE	WEIGHT (kg)
LG00780S	0,5
LG00781S	1
LG00782S	1,5
LG00783S	2
LG00784S	2,5



- > 50 mm internal diameter
- > Suitable for olympic bar steel



## TRAINING BUMPER PLATE

CODE	WEIGHT (kg)	COLOR
LG00790	5	Black
LG00791	10	Black
LG00792	15	Black
LG00793	20	Black
LG00794	25	Black



- > Indoor use
- > Fast to place and remove

## PRO BUMPER PLATE COLOR

CODE	WEIGHT (kg)	COLOR
LG00795	5	Grey
LG00796	10	Green
LG00797	15	Yellow
LG00798	20	Blue
LG00799	25	Red



- > Colored bumper for easy weight identification
- > Fast to place and remove

\*The product may differ from the image shown

## FRACTIONAL PLATE

CODE	WEIGHT (kg)
LG00780	0,5
LG00781	1
LG00782	1,5
LG00783	2
LG00784	2,5



- > Colored fractional plate for easy weight identification

## KETTLEBELL COMPETITION

CODE	WEIGHT (kg)
LG00200	8
LG00201	12
LG00202	16
LG00203	20
LG00204	24
LG00204	28
LG00206	32



- > All weights are the same size according to the international competition standards
- > Different colors for easy weight identification
- > Comfortable handle

## KETTLEBELL PRO

### COLORED RING

CODE	WEIGHT (kg)
LG00151	4
LG00152	6
LG00153	8
LG00154	10
LG00155	12
LG00157	16
LG00159	20
LG00160	22

CODE	WEIGHT (kg)
LG00161	24
LG00162	26
LG00163	28
LG00164	32
LG00165	36
LG00166	40
LG00167	44
LG00168	48



- > Powder coat finish for a better grip
- > Colored rings for easy weight identification
- > Flat base

## HEXAGON DUMBBELL

CODE	WEIGHT	CODE	WEIGHT
LG00052	2,5	LG00065	17,5
LG00055	5	LG00066	20
LG00059	7,5	LG00067	22,5
LG00062	10	LG00068	25
LG00063	12,5	LG00069	27,5
LG00064	15	LG00070	30



- > Hexagon rubber ends
  - > Ergonomic handle
  - > Long term durability
  - > Preserves surfaces
  - > Minimizes noise
- > from 1 kg to 10 kg - 1 kg increments - on request
  - > from 32 kg up to 50 kg - 2,5 kg increments - on request

## ROUND RUBBER DUMBBELL

CODE	WEIGHT	CODE	WEIGHT
LG00830	2,5	LG00836	17,5
LG00831	5	LG00837	20
LG00832	7,5	LG00838	22,5
LG00833	10	LG00839	25
LG00834	12,5	LG00840	27,5
LG00835	15	LG00841	30



- > Round dumbbell ends
  - > Knurling handle
  - > Preserves surfaces
- > from 1 kg to 10 kg - 1 kg increments - on request
  - > from 32 kg up to 50 kg - 2,5 kg increments - on request

## STEEL DUMBBELL

CODE	WEIGHT	CODE	WEIGHT
LG01101	4	LG01108	18
LG01102	6	LG01109	20
LG01103	8	LG01110	22
LG01104	10	LG01111	24
LG01105	12	LG01112	26
LG01106	14	LG01113	28
LG01107	16	LG01114	30



- > Round steel end with rubber border
- > Knurling handle

## WALL BALL

CODE	WEIGHT (kg)
LG00253	4
LG00255	6
LG00258	9
LG00261	12

- > New high resistance and soft-touch PU covering
- > Balanced inner load
- > Colored covering for easy weight identification



## SLAM BALL PRO

CODE	WEIGHT (kg)
LG01021	4
LG01023	6
LG01025	8
LG01027	10
LG01028	12

- > Specific for throwing and slamming exercises
- > Stronger outer layer



## POWER BAG

CODE	WEIGHT (kg)
LG00301	5
LG00302	10
LG00303	15
LG00304	20
LG00305	25

- > Equipped with 4 ergonomical handles
- > Balanced inner load
- > Colored covering for easy weight identification
- > High resistance vinyl covering



## SAND BALL

CODE	WEIGHT (kg)
JL-SBXT-LG	5 up to 12kg

- > Holds up to 12kg max
- > Includes No Leak inner sandbag liner
- > Holds up to the maximum individual bag sizes
- > Filler not included



## WEIGHTED VEST 9-10KG

CODE	WEIGHT (kg)
LGJ-GZ10N	10
LGJ-GZT9	9



LGJ-GZT9

Maximum load 10 Kg (20 removable inserts of 500 gr each)  
Maximum load 9 Kg (1plate of 4 Kg + 2 plates of 2 Kg)

## WEIGHTED VEST 20KG

CODE	WEIGHT (kg)
LGJ-GZ20N	20

> Maximum load 20 Kg (8 pcs of 2500 g removable insert)



## WEIGHTED VEST 30KG

CODE	WEIGHT (kg)
LGJ-GZ30	30

> Maximum load 30 Kg (30 pcs of 920 g removable insert)



## TIMER

CODE	DIMENSIONS (cm)
LG00622	34 x 10 x 4
LG00623	71 x 16 x 4,5

- > Tabata function
- > Countdown/count up
- > Clear audio



## WOODEN PLYOBOX

CODE	DIMENSIONS (cm)	WEIGHT (kg)
LG00352	40 x 50 x 60	13
LG00353	50 x 60 x 70	18

- > Easy to install
- > Very resistant
- > 3 different training heights



## LATEX BAND SET

CODE	VERSION
LG00408	5 different intensity

- > Set of bands for both training and rehabilitation exercises



## POWER BAND

CODE	DIMENSIONS (cm)	COLOR
LG00401	208 x 13	Red
LG00402	208 x 21	Black
LG00403	208 x 32	Purple
LG00404	208 x 45	Green
LG00405	208 x 64	Blue

- > Train resistance and mobility
- > 5 resistance levels
- > Different colors for easy identification



## WAIST BELT

<i>CODE</i>	<i>SIZE</i>
LGJ-FL-SM	S/M
LGJ-FL-LXL	L/XL

> Allows you to increase perspiration and at the same time compresses the lumbar and abdominal area



## AB MAT

<i>CODE</i>	<i>DIMENSIONS (cm)</i>
LG00503	38 x 30 x 7,2

- > Ergonomic design
- > Portable core training equipment
- > Handstand pushup training



## SHOCK ABSORPTION MATS

<i>CODE</i>	<i>DIMENSION (cm)</i>
LGJ-DL-MAT	76 x 60 x 15

> Shock absorption mats for barbell drop. PVC cover. Cotton foam interior



## SPEED ROPES

CODE	VERSION
LG00452	Plastic Handle
LG00453	Aluminium Handle

- > Ergonomic handles
- > High rotation speed
- > Adjustable length



## BATTLE ROPE

CODE	DIMENSIONS	COLOR
LG00523	9 m x 38 mm	Yellow - Black
LG00524	12 m x 38 mm	Yellow - Black
LG00525	15 m x 38 mm	Yellow - Black

- > Ergonomic handles
- > High-intensity power training



## CLIMBING ROPE

CODE	DIMENSIONS	COLOR
LG00540	4 m x 38 mm	Black
LG00541	6 m x 38 mm	Black
LG00542	8 m x 38 mm	Black

- > Used for military training and functional workouts
- > Metal hook for a safe anchoring





## WOODEN RINGS

<i>CODE</i>	<i>Ø (cm)</i>	<i>HANDLE</i>
LG00009	23,5	3cm wide

- > Ergonomic handles
- > High-intensity power training



## CROSS-WALL ANCHORAGE RING

<i>CODE</i>	<i>DIMENSIONS (cm)</i>
LGJ-AAD	12 x 12 x 6

- > Anchor ring for FST, TTED or accelerator



## HANDSTAND BOARD

<i>CODE</i>	<i>DIMENSIONS (cm)</i>
LG00820	105 x 250 x 0,5

- > Customizable with logo
- > Wear resistant
- > Wall installation
- > Pvc



## CROSS TRAINING SLED

<i>CODE</i>	<i>DIMENSIONS (cm)</i>
LGJ-SCT	84 x 112 x 103

> Equipped with 3 steel sliding pads and bayonet-mounted push bars.

Loadable tube suitable for 50 mm holes and upright with pins for 25 mm holes nylon cordura jacket with padded rags for traction exercises included



## CROSS TRAINING SLED MINI

<i>CODE</i>	<i>DIMENSIONS (cm)</i>
LGJ-SCT-M	96,4 x 60,5 x 28,3

> Super compact agility slide loading table equipped with 50 mm pin. Push handle. Equipped with nylon cordura jacket with padded rags



## DUMBBELL RACK

<i>CODE</i>	<i>DIMENSIONS (cm)</i>
LG00760	54 x 42 x 106

- > Holds up to 6 pairs
- > Space saving design
- > For Hex Dumbbell



## PARALLETTES MINI

<i>CODE</i>	<i>DIMENSIONS (cm)</i>
LGJ-PAR-M	59 x 36 x 30

> Steel tubes frame



## PARALLETTES LARGE

<i>CODE</i>	<i>DIMENSIONS (cm)</i>
LGJ-PAR-L	61 x 35 x 70,6

> Steel tubes frame with rubberized handles.



## LANDMINE BARBELL ROW

<i>CODE</i>	<i>PRODUCT</i>
LGJ-LAD	Max Load: 250 kg

> Base with no slip surface, gimbal with  $\varnothing 25$  /  $\varnothing 50$  mm barbell seats



## DUMBBELL STORAGE – 3 SHELVES (15 PAIRS)

<i>CODE</i>	<i>DIMENSIONS (cm)</i>
LGJ-RM-15P	230 x 74 x 140

> 3 shelves dumbbell storage. Fits 15 pairs dumbbells in the supplied seats



## DUMBBELL STORAGE – 2 SHELVES (10 PAIRS)

<i>CODE</i>	<i>DIMENSIONS (cm)</i>
LGJ-RMD-2R	230 x 74 x 90

> 2 shelves dumbbell storage. Fits 10 pairs dumbbells in the supplied seats.



## DUMBBELL STORAGE – 2 SHELVES

<i>CODE</i>	<i>DIMENSIONS (cm)</i>
LGJ-RME	s 122 x 53 x 89

> 2 shelves dumbbell storage. The rails free of seats allow intensive storage of hexagonal or round head dumbbells (end bulkheads prevent falling) up to 10/12 pairs



## KETTLEBELL STORAGE

**CODE**                      **DIMENSIONS (cm)**

LGJ-RKD                      122 x 65 x 81

> 2 shelves kettlebells storage. Rubber coated loading surfaces to increase the durability of the rack and of the kettlebells



## VYNIL DUMBBELL STORAGE

**CODE**                      **DIMENSIONS (cm)**

LGJ-RMVN                      95 x 62 x 121

> Storage dumbbells with vertical insertion. Locking bar makes it safe for collective use. Equipped with wheels and brakes.



## MULTI RACK

**CODE**                      **DIMENSIONS (cm)**

LGJ-MRD2                      56 x 148 x 96

> Plates / dumbbells / barbells / kettlebells storage. Ideal for personal training centers



## BODY PUMP SET STORAGE – 20

<i>CODE</i>	<i>DIMENSIONS (cm)</i>
LGJ-RLGJ-BPS-20	178 x 61 x 135

> 20 body pump sets rack.  
Equipped with plate holders, barbell seats and pins to store the collar springs



## BODY PUMP SET STORAGE - 12 SETS

<i>CODE</i>	<i>DIMENSIONS (cm)</i>
LGJ-RLGJ-BPS-12	76 x 68,2 x 156

> 12 body pump sets rack.  
Equipped with plate holders, barbell holder seats and pins for storing the disc holder



## POWER BAG/WALL BALL STORAGE

<i>CODE</i>	<i>DIMENSIONS (cm)</i>
LGJ-RPBD	56,6 x 68,7 x 142

> 5 shelves powerbags and balls storage.  
Each shelf has an additional seat to hold the balls.



## SLAM BALL STORAGE LARGE

<i>CODE</i>	<i>DIMENSIONS (cm)</i>
-------------	------------------------

LGJ-RSB-L	133,5 x 51 x 116
-----------	------------------

> 3 shelves storage balls: the 2 upper shelves are suitable for up to 16 cm diameters the lower level is instead designed for large diameters and high sizes



## SLAM BALL STORAGE - SMALL

<i>CODE</i>	<i>DIMENSIONS (cm)</i>
-------------	------------------------

LGJ-RSB-S	54 x 24,5 x 140,5
-----------	-------------------

> Vertical storage balls 10 seats.  
The width of the seats is variable to position different sizes



## POWER BAG STORAGE

<i>CODE</i>	<i>DIMENSIONS (cm)</i>
-------------	------------------------

LGJ-RPBD-1	67 x 64,5 x 170
------------	-----------------

> 4 seats powerbags storage



## GYM BALL STORAGE

<i>CODE</i>	<i>DIMENSIONS (cm)</i>
LGJ-RGB	135 x 185

- > Storage for gymballs with 8 seats.  
Chrome-plated steel support pole.  
Seat position adjustable in height and angle



## MAT STORAGE

<i>CODE</i>	<i>DIMENSIONS (cm)</i>
LGJ-RTF	71 x 60 x 185

- > Mats storage with adjustable eyelet pins.  
Equipped with pivoting transport wheels with brake



## WALL MAT STORAGE

<i>CODE</i>	<i>DIMENSIONS (cm)</i>
LGJ-RTF-W	70 x 26 x 6

- > Wall mount mat storage with adjustable eyelet pins.





## OLYMPIC PLATE AND BARBELL STORAGE

<i>CODE</i>	<i>DIMENSIONS (cm)</i>
LGJ-RDO-B	60 x 60 x 126

> 6 plate holders with a diameter of 50 mm at such a distance from each other that they also hold bumper models, and 6 barbell holder at the base with a diameter of 50 mm.



## OLYMPIC PLATE STORAGE

<i>CODE</i>	<i>DIMENSIONS (cm)</i>
LGJ-RD50	60 x 60 x 100

> has 3 arms plate and 6 pins to accommodate plates with a 50 mm hole



## BUMPER PLATE STORAGE

<i>CODE</i>	<i>DIMENSIONS (cm)</i>
LGJ-RD0	154 x 32,5 x 29,5

> Plates holder thickness: 2 x 108 mm - 2 x 96 mm - 2 x 71 mm - 2 x 60 mm - 2 x 27 mm - 4 x 50 mm



# WALL FIXING PULL UP MUSCLE-UP BAR



<i>CODE</i>	<i>DIMENSIONS (cm)</i>
LG00951	105 x 95

> 34cm handle grip



# WALL PULL-UP BAR

<i>CODE</i>	<i>DIMENSIONS (cm)</i>
LGJ-BT-W	132,5 x 54,5 x 95

> Grip possibilities: parallel – straight – oblique – symmetrical and asymmetrical.

Tube size: 50 x 50 x 2 mm, 25 x 50 x 2 mm, Ø 32 x 2 mm



# MODULAR & CUSTOM RIGS

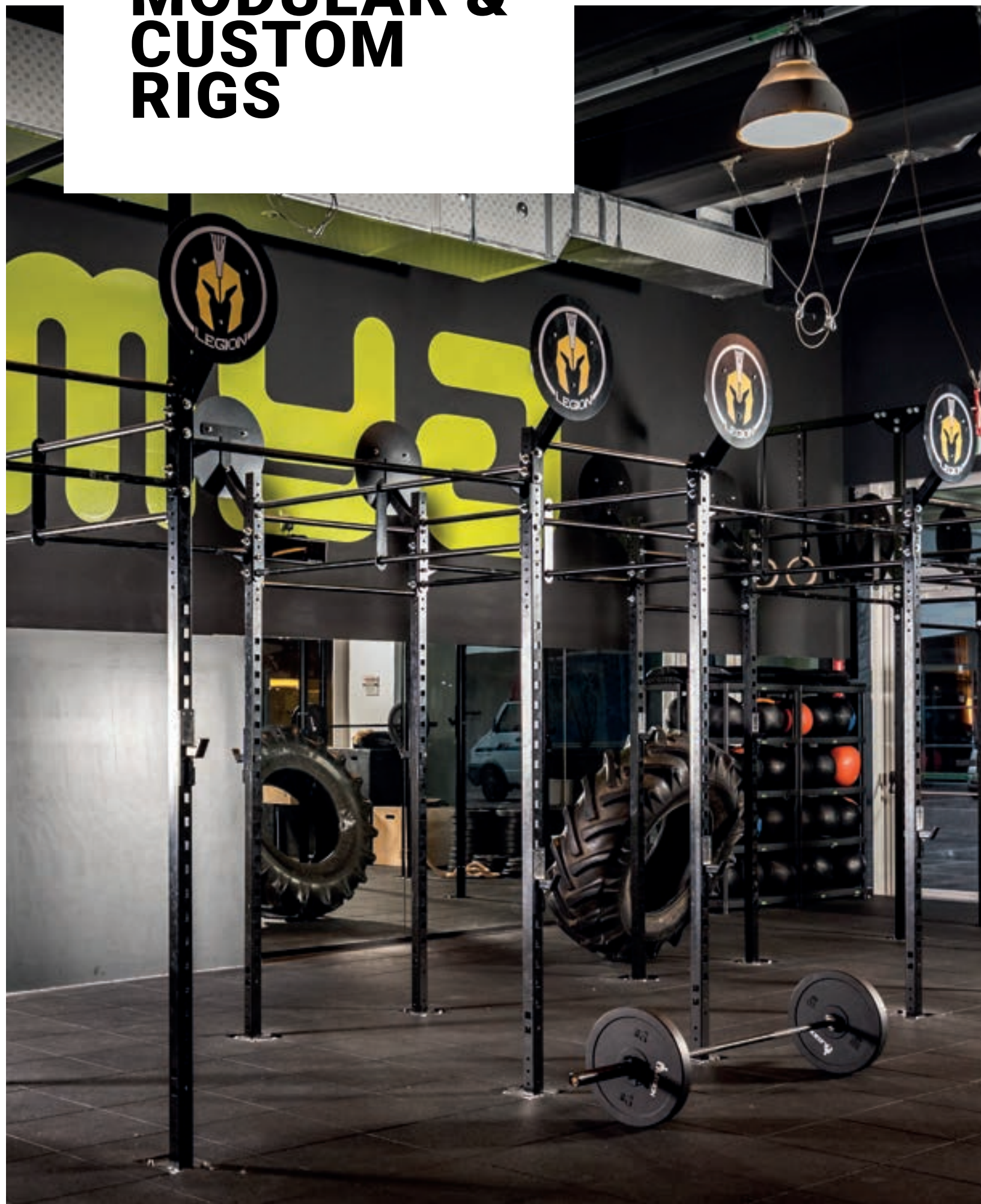

# PRAETORIAN STANDING RIG

CODE	DIMENSIONS (cm)	RACK STATION	PULLUP STATION
LP4	111 × 184 × h270	2	4
LP6	295 × 184 × h270	2	6
LP8	406 × 184 × h270	4	8
LP12	584 × 184 × h270	4	12

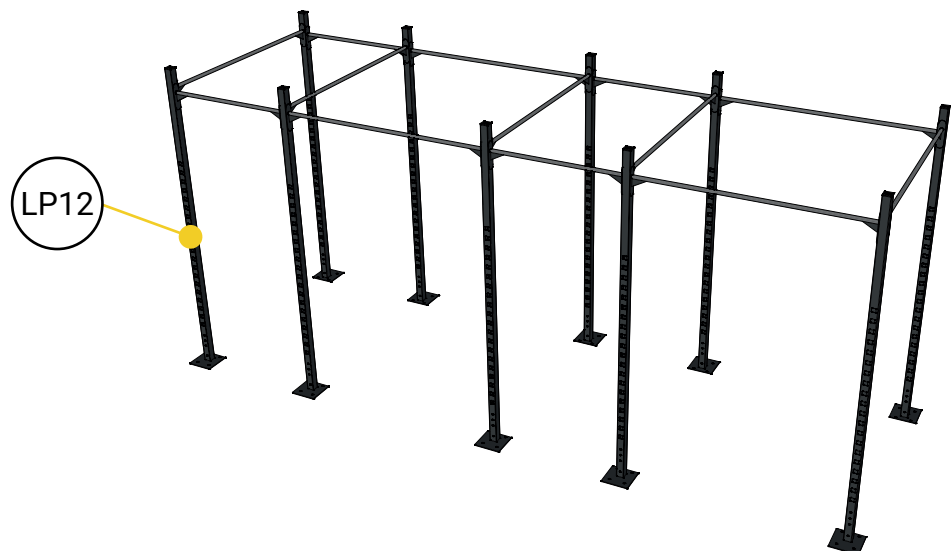
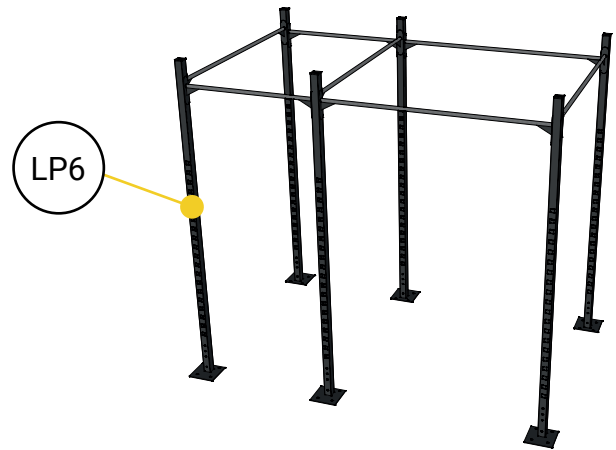

- > Design & colors customization
- > Indoor & outdoor use
- > Wide range of accessories

# CENTURION WALL MOUNTED RIG

CODE	DIMENSIONS (cm)	RACK STATION	PULLUP STATION
LC1	111 × 184 × h270	1	1
LC3	295 × 184 × h270	1	3
LC4	406 × 178 × h270	2	4
LC6	584 × 184 × h270	2	6

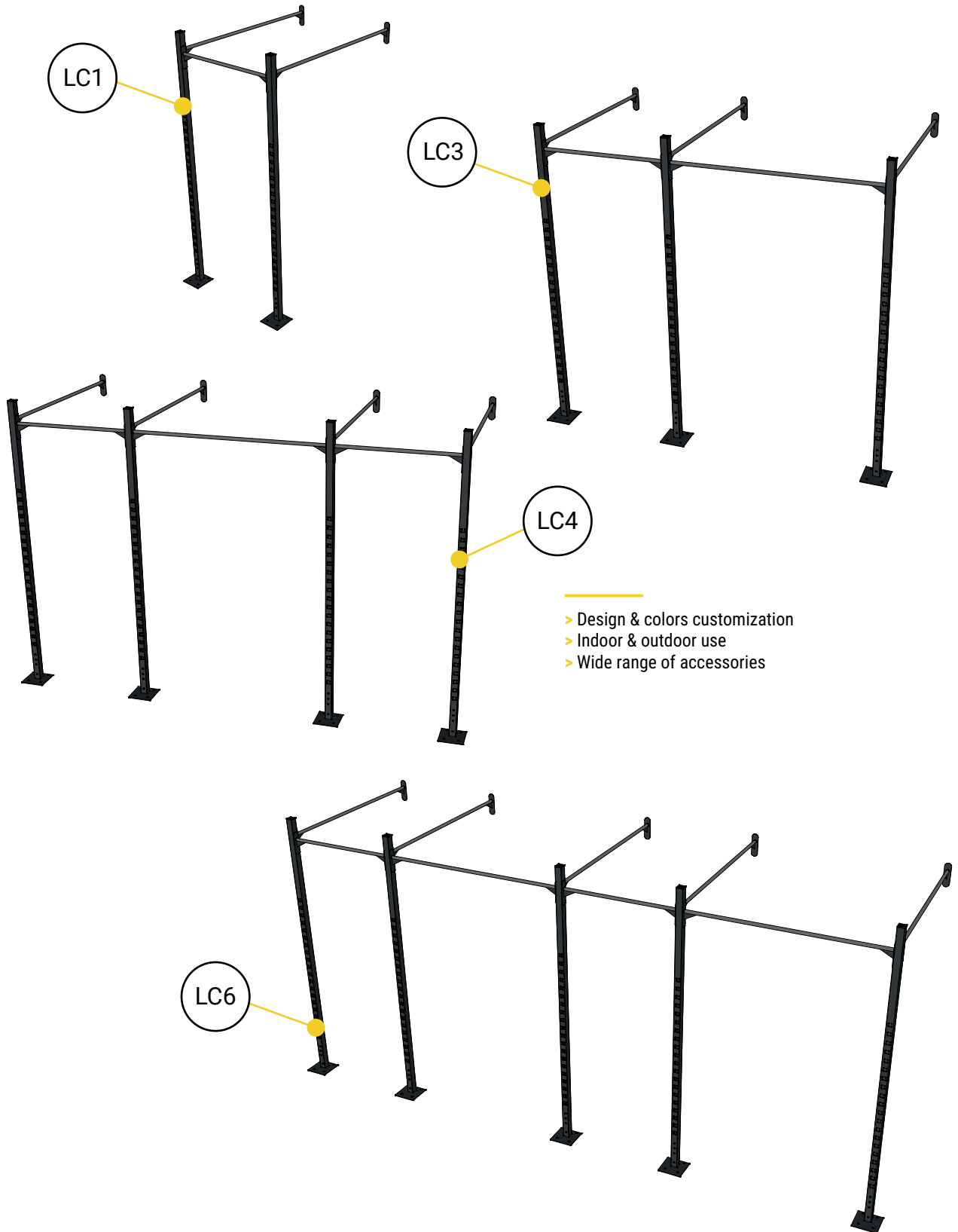

## RIG COLUMN

CODE	DIMENSIONS (cm)
F02001	6 x 6 x h 270
F02031	8 x 8 x h 270
F02002	6 x 6 x h 360
F02032	8 x 8 x h 360

## PULLUP BAR

CODE	VERSION
F02009	105 cm
F02010	105 cm (Pro Grip)
F02003	172 cm
F02004	172 cm (Pro Grip)

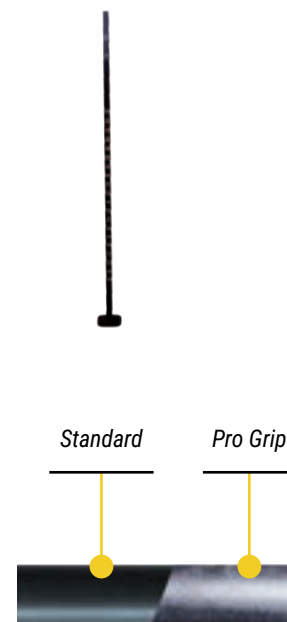

## DOUBLE PULLUP BAR

CODE	VERSION
F02011	105 cm
F02012	105 cm (Pro Grip)
F02005	172 cm
F02006	172 cm (Pro Grip)

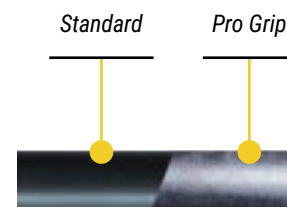

## TRIPLE PULLUP BAR

CODE	VERSION
F02013	105 cm
F02014	105 cm (Pro Grip)
F02007	172 cm
F02008	172 cm (Pro Grip)

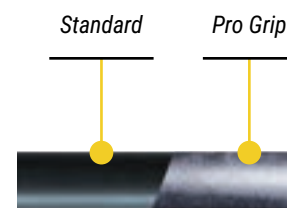

## HOOK SET

CODE	VERSION
F02015	Hook Set 6x6 (couple)
F02033	Hook Set 8x8 (couple)



## DIP STATION

**CODE**

F02017



## PULLUP LADDER 45°

**CODE**

F02018

**VERSION (width)**

105 cm

F02023

172 cm



## ROPE CLIMB FRAME

**CODE**

F02019



## SAFETY ARMS (COUPLE)

**CODE**

F02020



## BALL TARGET

**CODE**

F02021



## MONKEY BAR FRAME (5 X BARS)

**CODE**

F02025

**VERSION (width)**

105 cm

F02024

175 cm

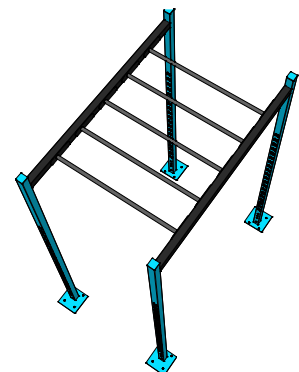

# STUDIO





# VYNIL DUMBBELL SET

<b>CODE</b>	<b>WEIGHT (kg)</b>
LGJ-MVD-S	1 - 10

> Vinyl dumbbell set (1-10 Kg) with triangular anti-roll head. Easily sanitized it's suitable for collective use



# ADJUSTABLE DUMBBELL

<b>CODE</b>	<b>WEIGHT (kg)</b>
LGJ-MS32S	3 - 32

> Unloaded dumbbell weight 3 Kg. 28 plates of 1 kg and 2 plates of 0,5 kg. Base weight 1,5 kg. Stainless steel plating and rustproof.



## WATER BAG

<i>CODE</i>	<i>WEIGHT (kg)</i>
LGJ-WB25L	25

> PVC bag Filled up to 25 Kg.  
Equipped with 4 padded nylon handles, suitable for workouts based on the instability weight



## GYM BALL

<i>CODE</i>	<i>DIMENSIONS</i>
LGJ-GB55	55
LGJ-GB65	65
LGJ-GB75	75
LGJ-GB85	85

> Available in 4 different colours



## PILATES BALL

<i>CODE</i>	<i>DIMENSIONS</i>
LGJ-PB25	25

> Ø 25 cm ball designed for resistance or strengthening work in pilates and yoga.



## SET BODY PUMP



<i>CODE</i>	<i>LENGHT (cm)</i>
LGJ-BPSD	140

> Contents of the kit: 3 pairs of rubber-coated plates with 31 mm hole, 2 x 1,25 kg plates, 2 x 2,5 kg plates, 2 x 5 kg plates, 1 non-slip foam-coated barbell with Ø 30 mm handle length 140 cm, 2 spring collars.

## BODY PUMP BARBELL



<i>CODE</i>	<i>LENGHT (cm)</i>
LGJ-BJKBPD	140

- > 30 mm handle diameter
- > Body pump barbell.
- > Handle Ø 30 mm
- > Loadable sleeve length 20 cm
- > Length 140 cm
- > Weight 2 Kg

## PAIR OF ABS BODY PUMP SAFE LOCK Ø30 MM

<i>CODE</i>	<i>PRODUCT</i>
LGJ-FP-LGJ-BP	Plastic



> Pair of ABS Body pump safe lock Ø 30 mm

## SPRING SAFETY COLLARS Ø 30 MM

<i>CODE</i>	<i>PRODUCT</i>
LGJ-MSD30	chrome-plated



> Pair of spring clip for body pump barbell Ø 30 mm

## WEIGHT BODY PUMP KIT

<i>CODE</i>	<i>WEIGHT (kg)</i>
LGJ-KPLGJBP	17,5



> 3 couples of plates for body pump barbell  
2 x 5 Kg - 2 x 2,5 Kg - 2 x 1,25 Kg.

## PVC STUDIO MAT WITH EYELETS

<i>CODE</i>	<i>LENGTH (cm)</i>
LGJ-TS1	140
LGJ-TS2	120
LGJ-TS3	170

> Double layer PVC mat.  
Extremely comfortable and easy to sanitize, it can be easily stored thanks to the double eyelet



## TPE YOGA MAT

<i>CODE</i>	<i>DIMENSIONS</i>
LGJ-TY	183 x 61 x 0,4

> 100% eco-friendly, PVC- and latex-free, hypoallergenic, recyclable and biodegradable fitness mat.



## NBR FITNESS

<i>CODE</i>	<i>LENGTH (cm)</i>
LGJ-TAO	180
LGJ-TAO120	120

> Easily rolled up and transportable mat with eyelets and carrying strap



## MASSAGE & YOGA ROLLER

<i>CODE</i>	<i>DIMENSIONS</i>
LGJ-RY	Ø 14 x 33 cm

> Tension-relieving EVA foam massage roller for rehabilitation training.



## PILATES ROLLER

<i>CODE</i>	<i>DIMENSIONS</i>
LGJ-PR91	Ø 15 x 91

> Material that is crushproof, light and at the same time compact.



## ABDOMINAL WHEEL R-AB1

<i>CODE</i>	<i>DIMENSIONS (cm)</i>
LGJ-R-AB1	23 x 23 x 20

> Abdominal wheel 23 x 23 x 20 cm, with oneway elastic resistance to assist the movement and reduce the risk of injury



## PILATES ROLLER R-AB2

<i>CODE</i>	<i>DIMENSIONS (cm)</i>
LGJ-R-AB2	25,5 x 21,5 x 14

> Abdominal wheel 25,5 x 21,5 x 14 cm, with one-way elastic resistance to assist movement and reduce the risk of injury



# TRUCK TIRE

CODE	DIMENSIONS (cm)	WEIGHT (kg)
LG01035	diam. 100 - h 35	60

- > Suitable for fitness, functional, crosstraining and bootcamp workouts
- > Covered with an extra heavy PVC anti-slip material which ensure durability when it is dragged



# SOFT PLYO BOX PRO

CODE	DIMENSIONS (cm)	WEIGHT (kg)
LG01034	50 x 60 x 75	25

- > Absorbs the impact of landing and eases the shock on ankles, knees and hips
- > Perfect for introducing beginners to plyometrics



# PLYO BOX SOFT PRO

CODE	USER WEIGHT (kg)
LGJ-PBSD-P	Max user weight:150

- > Can be positioned to work at three different heights (51, 61 or 76 cm) to adjust the training difficulty



## STEP



<i>CODE</i>	<i>DIMENSIONS (cm)</i>
LG01032	90 x 35 x 18

- > Anti-slip surface
- > Suitable for fitness, aerobics and cardio workouts



## AEROBIC STEP 99 X 38 CM

<i>CODE</i>	<i>DIMENSIONS (cm)</i>
LGJ-PSD	98 x 38 x 15 (20/25)

- > Non-slip surface step
- > Adjustable in 3 levels
- > Interlocking feet



## AEROBIC STEP 110 X 41 CM

<i>CODE</i>	<i>DIMENSIONS (cm)</i>
LGJ-AS	110 x 40 x 11 / 16 / 21

- > Non-slip surface step
- > Adjustable in 3 levels
- > Support plates





## FREESTANDING PUNCHING BAG



CODE	DIMENSIONS (cm)	WEIGHT (kg)
LG01031	diam. 35 - h 180	73

- > Punch bag for boxing and combat sports
- > It guarantees maximum absorption on impact



## FIT BOXE BAG

CODE	DIMENSIONS (cm)
LGJ-SFB	diam. 40 - h 190

- > Fit boxe bag adjustable in 3 levels
- > Base fillable with water or sand
- > Bag dimensions Ø 40 x 142 cm
- > Base dimensions 54 cm x Ø 68 cm
- >



## BOXING BAG

<i>CODE</i>	<i>DIMENSIONS (cm)</i>	<i>WEIGHT (kg)</i>
LGJ-SB140	140	40

> 40 Kg boxing bag, h 140 cm, complete with chain and suspension hook.  
High resistance polyvinyl coating



## PUNCHING BAG PLAIN



MADE IN ITALY

<i>CODE</i>	<i>DIMENSIONS (cm)</i>	<i>WEIGHT (kg)</i>
LG01030	diam. 35 - h 100	30

> Punch bag for boxing and combat sports  
> It guarantees maximum absorption on impact



# SWEDISH ONE-SPAN WALL BARS

<i>CODE</i>	<i>DIMENSIONS (cm)</i>
LGJ-SV-1	90 x 250

> Swedish double-span wall bars in solid beech polished and treated with protective clear coat. Available in single or double version.



# SWEDISH DOUBLE-SPAN WALL BARS

<i>CODE</i>	<i>DIMENSIONS (cm)</i>
LGJ-SV-2	180 x 250

> Swedish double-span wall bars in solid beech polished and treated with protective clear coat. Available in single or double version.



76

# PROGETTIAMO LA TUA AREA TRAINING SU MISURA PER TE

*taylor-made  
for you!*

**SCOPRI LA VASTA GAMMA DI  
SUPERFICI TECNICHE DOTILE FIT**



**D** **FIT** **TiLE**

# VIRTUS



## FUNCTIONAL TRAINING SURFACES

CODE	DIMENSIONS (cm)	THICKNESS (mm)
P00591	50 x 50	10
P00511	50 x 50	15
P00501	50 x 50	20
P00532	50 x 50	30
F00871	100 x 100	10
F00874	100 x 100	15
F00877	100 x 100	20
F00883	100 x 100	30

### TECHNICAL FEATURES

- > Stable
- > Easy to install
- > Easy to clean

### PERFORMANCE FEATURES

- > Rebound Control
- > Shock Absorbition Technology
- > Grip

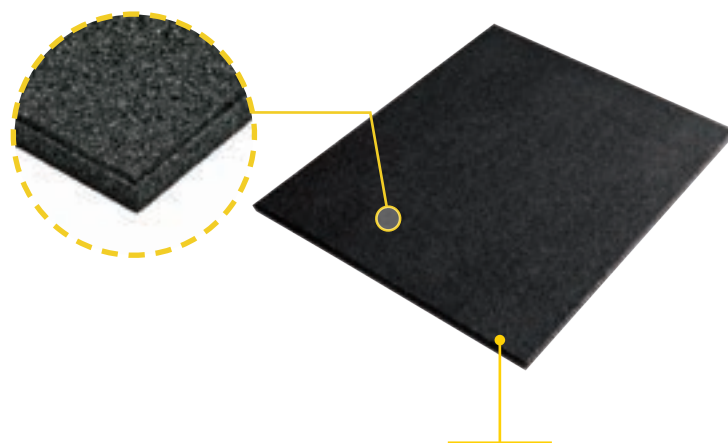

\*available pixel color tiles on request



# VIRTUS - S



## ULTRA FINE RUBBER MATS

CODE	DIMENSIONS (cm)	THICKNESS (mm)
F00891	100 x 100	10
F00894	100 x 100	15
F00897	100 x 100	20
F00903	100 x 100	30

### TECHNICAL FEATURES

- > Ultra Resistant
- > Easy to install
- > Easy to clean

### PERFORMANCE FEATURES

- > Rebound Control
- > Shock Absorbition Technology
- > Comfort

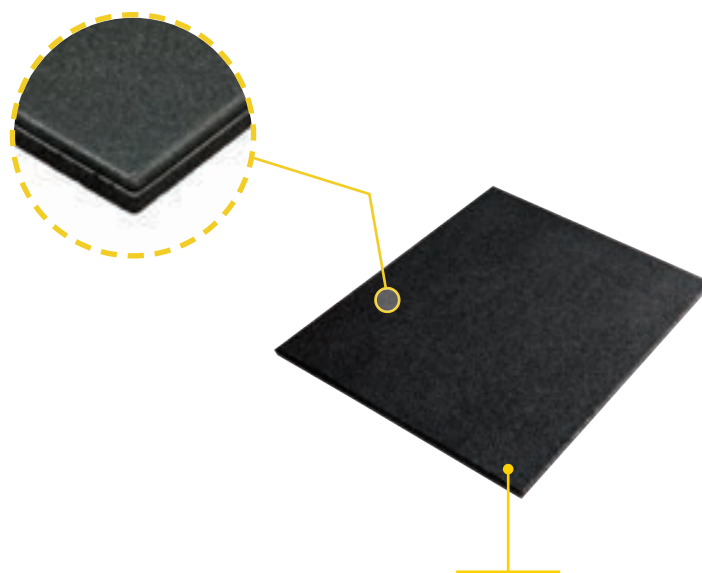

\*available pixel color tiles on request



# INTERLOCK TILES



## EASY INTERLOCKING

CODE	DIMENSIONS (cm)	THICKNESS (mm)
F00831	100 x 100	10
F00832	100 x 100	15
F00833	100 x 100	20

### TECHNICAL FEATURES

- > Stable
- > Easy to install
- > Easy to clean

### PERFORMANCE FEATURES

- > Rebound Control
- > Shock Absorbition Technology
- > Comfort

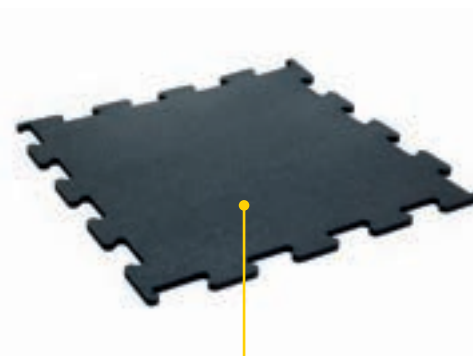

\*available pixel color tiles on request



## RUBBER ROLL

CODE	DIMENSIONS (cm)	THICKNESS (mm)
F00851	125 x 1000	6
F00852	125 x 800	8
F00853	125 x 600	10

### TECHNICAL FEATURES

- > Suitable for free-body training
- > Easy to transport
- > Easy to clean



## TATAMI



CODE	DIMENSIONS (cm)	THICKNESS (mm)	COLOR
F00601	100 x 100	20	Black / Grey
F00602	100 x 100	22	Blue / Red

- > Suitable for martial art areas
- > Easy to install



## ARTIFICIAL TURF COMFORT



CODE	DIMENSIONS (cm)	THICKNESS (mm)	COLOR
F00952	200 x 2500	20	Grass

### TECHNICAL FEATURES

- > Suitable for warm up or body-weight exercises
- > Easy to install



## ARTIFICIAL TURF SLED PATH



CODE	DIMENSIONS (cm)	VERSION	THICKNESS (mm)	COLOR
F00960	100 x 3000	L	5	Grass
F00970	200 x 2500	L	5	Grass
F00961	100 x 2500	H	10	Grass

### TECHNICAL FEATURES

- > Suitable for sled track area
- > Suitable for warm up or body-weight exercises
- > Easy to install



# SPRINT TRACK

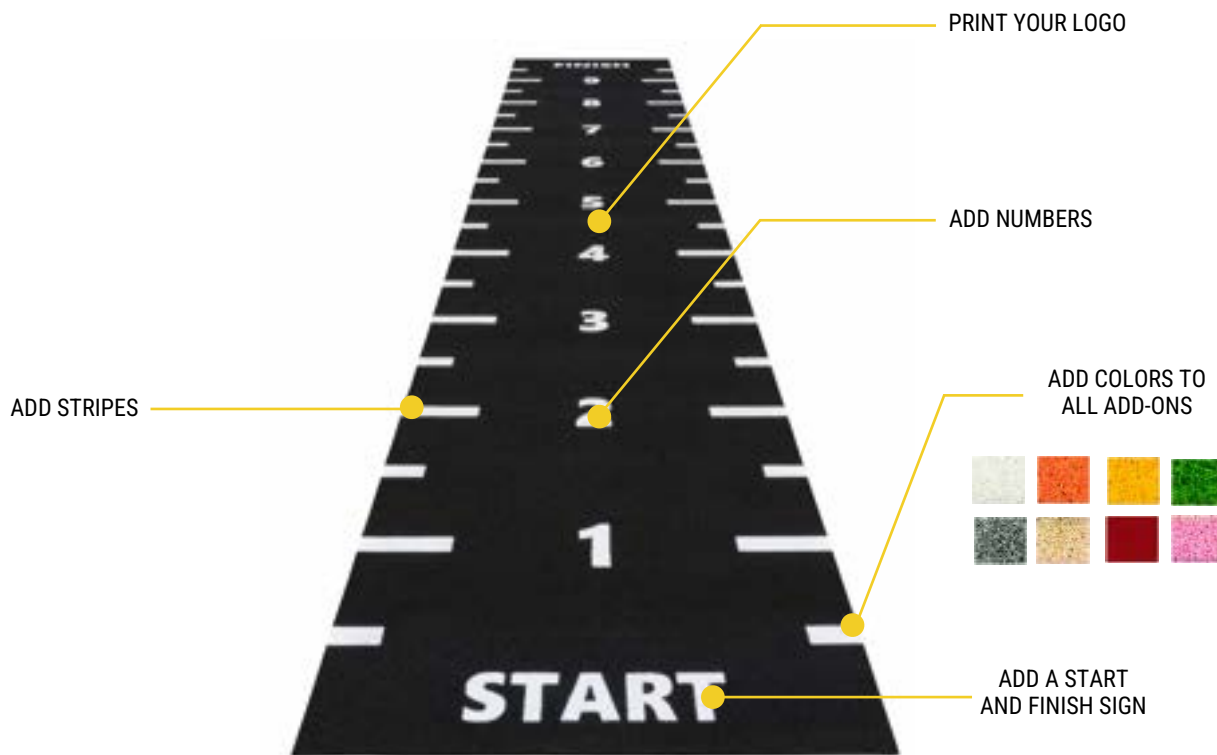

## CHOICE OF 5 DIFFERENT COLOURS



- > For sled track area
- > Easy to install
- > Wide range of colours
- > Customizable Logo and Color
- > Thickness: 13 mm



## MAGNITUDO

### THE WEIGHTLIFTING PLATFORM



CODE	PRODUCT	DIMENSIONS (cm)	THICKNESS (mm.)
P00707	AS1	255 x 205	30
P00708	AS2	255 x 255	30
P00709	AM1	305 x 255	30
P00710	AM2	305 x 305	30



#### TECHNICAL FEATURES

- > Developed with the Italian Weightlifting Federation
- > Composed with tiles made with different grains density
- > High shock absorption
- > High noise absorption

## OLYMPIC LIFTING PLATFORM



CODE	PRODUCT	DIMENSIONS (cm)	THICKNESS (mm.)
P00704	WM1	305 x 255	30



#### TECHNICAL FEATURES

- > Developed with the Italian Weightlifting Federation
- > Central wooden section for the olympic lifting
- > High noise absorption
- > High shock absorption

## FLOORING CLEAN SYSTEM

DIMENSIONS (cm)	WEIGHT (kg)
30 x 35 x 111	20

- > Clean and dry your technical surfaces using only one product
- > Cleaning system with two counter-rotating roller brushes
- > Solid structure, built with resistant materials
- > Practical and safe use
- > Removable tanks
- > Low energy consumption

- > Pulisci ed asciughi le superfici tecniche utilizzando un solo prodotto
- > Sistema di pulizia con due spazzole a rullo contro-rotanti
- > Struttura solida, costruita con materiali resistenti
- > Utilizzo pratico e sicuro
- > Serbatoi estraibili
- > Basso consumo energetico





## AIR BIKE

CODE	WEIGHT (Kg)
F00799	50

- > Train arms and legs simultaneously;
- > Computer with 7 different programs;

- > Alleni braccia e gambe simultaneamente
- > Dotato di 7 programmi diversi



## ROWERG



CODE	MODEL
IRCONC2D	Indoor Rower Mod.D Mon.

- > Indoor training;
- > The sophisticated monitor provides precise and immediate data on the training performance;

- > Adatto per l'allenamento indoor
- > Il monitor fornisce dati precisi ed immediati durante l'allenamento

## RUNMILL

CODE	DIMENSIONS (cm)	WEIGHT (kg)
BH-G669	187 x 93,4 x 166	180

- > Curved carpet without motor
- > 6 levels of frictional resistance
- > 5" LCD console
- > Aluminium and polyurethane slats

- > Tapisroulant curvo senza motore
- > 6 livelli di resistenza
- > Schermo LCD da 5"
- > Piano da corsa in alluminio e poliuretano

## BH FITNESS



## EXERCYCLE

CODE	DIMENSIONS (cm)	WEIGHT (kg)
BH-H9365	140 -144 x 61 x h114 -136	25

- > Electronic sequential shifting
- > Electromagnetic braking system
- > Support for smartphones and tablets up to 12.9"
- > Wheels for movement

- > Cambio sequenziale elettronico
- > Sistema di frenata elettromagnetico
- > Supporto per smartphone e tablet fino 12,9"
- > Rotelle per lo spostamento

## BH FITNESS



> La mia lista dei desideri

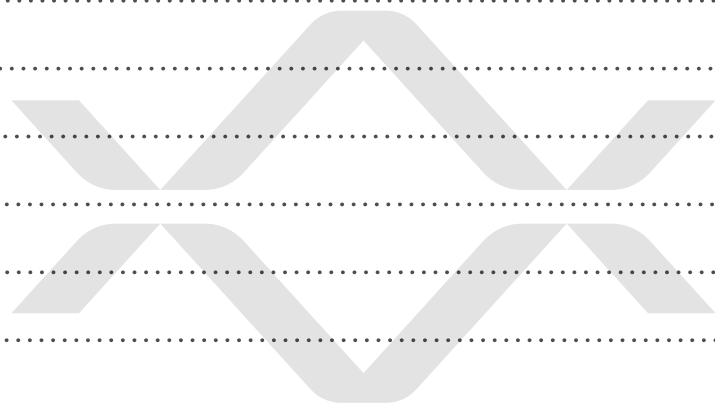

METEM

FIT

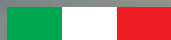

Per aziende e professionisti:

[www.metem.fit](http://www.metem.fit)

E-commerce per privati:

[www.dotile.it](http://www.dotile.it)

Metem srl is the owner of **DoTile® Fit**, **LEGION® Equipment**, **RamBOX®** and **Power Cuff** brands

TREVISO (*Italy*) - [team@metem.fit](mailto:team@metem.fit) - T. +39 **0422 26 70 10**